



# ANNY<sup>®</sup> 12

12" PORTABLE BATTERY-POWERED BLUETOOTH<sup>®</sup> PA SYSTEM WITH MIXER  
LDANNY12; LDANNY12BPH; LDANNY12BPH2; LDANNY12HBH2; LDANNY12HHD;  
LDANNY12HHD2;



---

# TABLE OF CONTENTS

<b>1</b>	<b>DOCUMENT VERSION AND REVISIONS .....</b>	<b>7</b>
<b>2</b>	<b>INTRODUCTION .....</b>	<b>8</b>
2.1	You Made the Right Choice! .....	8
2.2	Contacts.....	8
2.3	Link to the Download Centre.....	8
2.4	Visualisation Conventions in This User Manual.....	9
<b>3</b>	<b>PRODUCT COMPLIANCE .....</b>	<b>10</b>
3.1	Manufacturer's Declaration.....	10
3.2	Declaration of Conformity .....	10
<b>4</b>	<b>SAFETY INSTRUCTIONS.....</b>	<b>12</b>
4.1	Intended Use .....	12
4.2	Explanation of Safety and Warning Symbols.....	12
4.3	Structure of Warning Messages.....	13
4.4	General Safety .....	13
4.5	Electrical Safety.....	14
4.6	Physical Safety .....	15
4.7	Thermal Safety .....	15
4.8	Wireless Safety.....	15
4.9	Device Safety.....	16
4.10	Battery Safety.....	16
<b>5</b>	<b>PRODUCT DESCRIPTION .....</b>	<b>18</b>
5.1	Product Overview .....	18
5.2	Product Variants.....	18
5.3	Optional Accessories.....	20
5.4	Dimensions.....	20
5.5	Technical Data .....	21
5.6	User Interface Overview.....	24
<b>6</b>	<b>PREPARATION .....</b>	<b>26</b>
6.1	Scope of Delivery .....	26

6.2	Transport.....	26
6.2.1	Transport Handle Overview .....	27
6.2.2	Pulling Out the Handle .....	27
6.2.3	Pushing in the Handle .....	27
6.3	Using the Mobile Device Tray and Accessory Compartment .....	28
<b>7</b>	<b>INSTALLATION.....</b>	<b>29</b>
7.1	Mounting the ANNY® 12 on a Stand or a Speaker Pole.....	29
<b>8</b>	<b>OPERATION.....</b>	<b>30</b>
8.1	Power Supply.....	30
8.1.1	Connecting a Mains Power Cable.....	30
8.1.2	Using the ON / OFF / CHARGE Switch.....	30
8.1.3	Disconnecting the Mains Power Cable.....	30
8.2	Navigating the Device .....	31
8.2.1	Using the Rotary-Push Encoder .....	31
8.2.2	Accessing the Settings Section.....	31
8.3	Device Display Overviews.....	31
8.3.1	Main Screen Overview.....	31
8.3.1.1	Bluetooth® Setting Overview .....	32
8.3.1.2	Audio Settings Overview .....	33
8.3.1.3	Effects Menu Overview.....	34
8.3.1.4	System Setting Overview.....	34
8.4	True Wireless Stereo (TWS).....	35
8.4.1	About True Wireless Stereo (TWS) .....	35
8.5	Input Connections.....	35
8.5.1	Connecting an Input Source to the MIC / LINE Input.....	35
8.5.2	Bluetooth® for Audio Playback Mono Mode.....	35
8.5.2.1	Pairing a Mobile Device via Bluetooth® for Audio Playback .....	36
8.5.2.2	Unpairing a Bluetooth® Device .....	36
8.5.3	Bluetooth® for Audio Playback Stereo Mode .....	37
8.5.3.1	Linking two ANNY® 12 Devices via True Wireless Stereo (TWS).....	37
8.5.4	Unlinking TWS Connection .....	39
8.6	Audio Playback.....	39

8.6.1	Adjusting the Main Volume .....	39
8.6.2	Adjusting the Channel Volume.....	39
8.6.3	Using the Footswitch.....	39
8.7	RF Connections.....	40
8.7.1	Receiver Module.....	40
8.7.1.1	About Receiver Modules .....	40
8.7.1.2	Receiver Module Overview .....	41
8.7.1.3	Turning the Receiver Module on or off.....	41
8.7.1.4	Adjusting the Receiver Volume .....	41
8.7.1.5	About Mute Level.....	41
8.7.1.6	Adjusting the Receiver Module Mute Level .....	42
8.7.2	Transmitters.....	42
8.7.2.1	Handheld Transmitter Overview .....	42
8.7.2.1.1	Adjusting the Input Sensitivity of the Handheld Transmitter .....	43
8.7.2.1.2	Replacing the Batteries of the Handheld Transmitter .....	43
8.7.2.1.3	Syncing a Handheld Transmitter to a Receiver .....	43
8.7.2.2	Bodypack Transmitter Overview.....	44
8.7.2.2.1	Mini-XLR Input PIN-Assignment Overview.....	44
8.7.2.2.2	Replacing the Batteries of the Bodypack Transmitter .....	44
8.7.2.2.3	Syncing a Bodypack Transmitter to a Receiver .....	45
8.7.2.3	Adjusting the Input Sensitivity of the Bodypack Transmitter .....	45
8.7.2.3.1	Increasing the Input Sensitivity of the Bodypack Transmitter.....	45
8.7.2.3.2	Decreasing the Input Sensitivity of the Bodypack Transmitter .....	46
8.8	Output Connections .....	46
8.8.1	MIX OUT.....	46
8.8.1.1	Linking Different Anny Devices via MIX OUTPUT.....	46
8.9	Battery Compartment Overview.....	46
8.9.1	Charging Device Batteries.....	47
8.9.2	Replacing Device Batteries .....	47
8.10	Replacing the Fuse.....	48
<b>9</b>	<b>MAINTENANCE .....</b>	<b>49</b>
9.1	Product Maintenance .....	49
9.2	Storing the Device.....	49

---

9.3	Troubleshooting.....	50
9.4	Resetting the Device to Factory Settings.....	50
9.5	Repair.....	51
<b>10</b>	<b>DISPOSAL .....</b>	<b>52</b>
10.1	Packaging Disposal.....	52
10.2	Device Disposal.....	52
10.3	Battery Disposal.....	52
	<b>INDEX .....</b>	<b>53</b>

## 1 DOCUMENT VERSION AND REVISIONS

Version	Date	Implemented Changes
1	11/2025	Original version

## 2 INTRODUCTION

### 2.1 YOU MADE THE RIGHT CHOICE!

This product has been developed and manufactured to the highest quality standards to ensure many years of problem-free operation. Find further information about LD Systems on our website:

<https://www.ld-systems.com/>

### 2.2 CONTACTS

	<b>Adam Hall GmbH Headquarter</b>	<b>Customer Service</b>
E-mail	info@adamhall.com	customerservice@adamhall.com
Phone	+49 6081 9419-0	+49 6081 941973-0
Street	Adam-Hall-Str. 1	Adam-Hall-Str. 1
Postal code / city	61267 Neu-Anspach	61267 Neu-Anspach
Website	<a href="http://www.adamhall.com">www.adamhall.com</a>	<a href="http://www.adamhall.com">www.adamhall.com</a>

### 2.3 LINK TO THE DOWNLOAD CENTRE



You can download some information, such as CAD data or technical data, from the Download Centre. Scan the QR code or click the link to download this information:



## 2.4 VISUALISATION CONVENTIONS IN THIS USER MANUAL

In this manual we use graphical symbols and icons in certain contexts. Find below a table with explanations and use cases of the graphical symbols and icons.

Icon / Symbol	Designation	Context	Explanation / Example
✓	<b>Prerequisite</b>	Tasks	Used in task topics to indicate a prerequisite that must be met before beginning the task.
⇒	<b>Result / Intermediate Result</b>	Tasks	Used in task topics to indicate a result or intermediate result of an action step.
<b>1</b> Step <b>a)</b> Substep	<b>1 Action Step</b> <b>a) Substep</b>	Tasks	Used in task topics to indicate action steps and substeps.
<b>1</b>	<b>Callout</b>	Graphics; tasks	Text-image reference or labeling of certain functions on the device
[...]	<b>Value range indicator</b>	Technical data; paragraphs; lists	Indicates the range of a value, such as "Compressor ratio: <b>1:1...20:1</b> ". Mostly used in tables or callouts.
*	<b>Asterisk</b>	Paragraphs; tables	Indicates additional information in a footnote.
The <b>LIM</b> LED lights up	<b>General User Interface element</b>	Paragraphs; tasks; tables; lists	The words presented in this way represent graphic user interface elements on the device.
<b>PAGE</b> button	<b>Key / Button</b>	Paragraphs; tasks; tables; lists	The words presented in this way represent user interface controls on the device.
<name>	<b>User input</b>	Paragraphs; tasks; tables; lists	The words presented in this way represent required user inputs.
<u><a href="https://adamhall.com">https://adamhall.com</a></u>	<b>Weblink</b>	Paragraphs; tables; lists	External link to a website

## 3 PRODUCT COMPLIANCE

### 3.1 MANUFACTURER'S DECLARATION

Adam Hall offers a voluntary, EU-wide manufacturer's guarantee of 2 years. The statutory warranty period is not affected by this voluntary guarantee.

Visit the Adam Hall Service Portal to access the **Download Centre**:

<https://portal.adamhall.com/>

Under the **Service & Regulations** section, you find our current detailed manufacturer's declarations, warranty conditions, and limitation of liability.

To request warranty for a product, please contact:

Adam Hall GmbH, Adam-Hall-Str. 1, 61267 Neu-Anspach

customerservice@adamhall.com

0049 (0)6081 / 9419-1000

### 3.2 DECLARATION OF CONFORMITY



Hereby, Adam Hall Ltd. declares that this product meets the following guidelines (where applicable)

- Electrical Equipment (Safety) Regulations 2016
- Electromagnetic Compatibility Regulations 2016 (SI 2016/1091)
- The Restriction of the Use of Certain Hazardous Substances in Electrical and Electronic Equipment Regulation 2012 (SI 2012/3032)
- Radio Equipment Regulations 2017 (SI 2016/2015)

Products that are subject to Electrical Equipment(Safety)Regulation 2016, EMC Regulation 2016 or RoHS Regulation can be requested at info@adamhall.com. Products that are subject to the Radio Equipments Regulations 2017 (SI2017/1206) can be downloaded at <http://www.adamhall.com/compliance>.

#### FCC STATEMENT



This device complies with part 15 of the FCC Rules. Operation is subject to the following two conditions:

1. This device may not cause harmful interference.
2. This device must accept any interference received, including interference that may cause undesired operation.

**⚠ CAUTION! RF Exposure Information: This equipment complies with FCC radiation exposure limits set forth for an uncontrolled environment. This equipment should be installed and operated with minimum distance 20 cm between the radiator and your body.**

**⚠ CAUTION! Any changes or modifications to this device not explicitly approved by the manufacturer could void your authority to operate this equipment.**

This equipment has been tested and found to comply with the limits for a Class B digital device, pursuant to part 15 of the FCC Rules. These limits are designed to provide reasonable protection against harmful interference in a residential installation. This equipment generates, uses and can radiate radio frequency energy and, if not installed and used in accordance with the instructions, may cause harmful interference to radio communications. However, there is no guarantee that interference will not occur in a particular installation. If this equipment does cause harmful interference to radio or television reception, which can be determined by turning the equipment off and on, the user is encouraged to try to correct the interference by one or more of the following measures:

- Reorient or relocate the receiving antenna.
- Increase the separation between the equipment and receiver.
- Connect the equipment into an outlet on a circuit different from that to which the receiver is connected to.
- Consult the dealer or an experienced radio/TV technician for help.

### **ISED STATEMENT**

This device contains licence-exempt transmitter(s)/receiver(s) that comply with Innovation, Science and Economic Development Canada's licence-exempt RSS(s). Operation is subject to the following two conditions:

1. This device may not cause interference.
2. This device must accept any interference, including interference that may cause undesired operation of the device.

The digital apparatus complies with Canadian CAN ICES-003 (B)/NMB-003(B).

This equipment complies with IC RSS-102 radiation exposure limits set forth for an uncontrolled environment.

This equipment should be installed and operated with minimum distance 20 cm between the radiator and your body.

This device meets the exemption from the routine evaluation limits in section 2.5 of RSS 102 and compliance with RSS 102 RF exposure, users can obtain Canadian information on RF exposure and compliance.

## 4 SAFETY INSTRUCTIONS

### 4.1 INTENDED USE

This device is intended for mobile audio applications. It is equipped with wheels and a retractable handle for transport on flat surfaces. It allows amplification of microphone and line signals, Bluetooth® audio playback, and signal processing via integrated mixer with EQ and effects. It supports wireless microphone operation, battery-powered use, and speaker pole mounting.

This product has been developed for the professional use in the field of event technology, studio, TV, and broadcast.

The device is intended for mobile applications and not for fixed installations.

The device is intended for indoor use only.

It is suitable for domestic use.

Do not use the product outside the operating conditions as stated in the user manual under Technical Data. Liability for damage and third-party damage to persons and property due to inappropriate use is excluded.

This product is not suitable for children and persons with limited physical, sensory, or mental capabilities or lack of experience and knowledge.

### 4.2 EXPLANATION OF SAFETY AND WARNING SYMBOLS

Find the following safety and warning symbols on the device, the user manual, or the packaging:



This symbol indicates that you must read the complete user manual before using the product.



This symbol indicates a general hazardous situation.



This symbol indicates hazards that can cause electric shock.



This symbol indicates tripping hazards.



This symbol indicates high sound pressure levels.



This symbol indicates hazards due to corrosive substances.



This symbol indicates hazards due to toxic substances.



This symbol indicates hazards due to leaking batteries.



This symbol indicates pinching hazards.



This symbol indicates hazards due to overhead loads.



This symbol indicates that the product is for indoor use only.



This symbol indicates that the product has no serviceable parts. Only authorized personnel is allowed to perform maintenance or service work.



This symbol indicates helpful hints or additional information.

### 4.3

## STRUCTURE OF WARNING MESSAGES

In this user manual, warning messages are structured with a safety symbol, a signal word, a hazard description, and instructions on how to avoid injuries or death.



**DANGER**

Indicates a hazardous situation which will result in death or serious injury.



**WARNING**

Indicates a hazardous situation which could result in death or serious injury



**CAUTION**

Indicates a hazardous situation which could result in minor or moderate injury.



**NOTICE**

Indicates situations or conditions that could result in damage to property and/or the environment.

### 4.4

## GENERAL SAFETY



- Read this document carefully.

- Keep this document for later reference.



- Follow closely the instructions in this document.



- This document is an integral part of the product. If you sell or pass on the product, you must include this document.

- Only use this product according to its intended use.

- Risk of choking. Keep small parts away from children and individuals with impaired physical, sensory, or mental capabilities.

- Risk of suffocation. Keep plastic bags away from children and individuals with impaired physical, sensory, or mental capabilities.

- Observe all safety instructions and warning messages in this document, on the device, and on the packaging.
- Products are subject to continuous further development. If you find discrepancies between this document and the product labeling, the information on the product always takes priority.
- Do not remove safety instructions or warning messages from the product.
- Do not open the device.
- Do not modify the product.
- If the product shows any sign of damage, do not use it.
- Do not operate the product with removed or missing covers.
- Do not expose the product to direct sunlight.
- If not further specified in the user manual under Technical Data, do not use the product in ambient temperatures that exceed 40 °C / 104 °F or fall below 0 °C / 32 °F
- Do not use the product in tropical climate.
- Do not use the product above 2000 metres of altitude.
- Unless otherwise stated, do not use the product under marine conditions.
- Use only accessories specified by the manufacturer.
- Maintenance and repairs may only be carried out by authorized service personnel.
- Store and transport the product in a dry and safe environment.
- Clean the product on a regular basis. If applicable, see the user manual for maintenance intervals.
- If the device was exposed to strong temperature changes, such as during transport, do not switch it on immediately. Wait until the device has reached ambient temperature.
- High sound pressure levels may cause hearing damage. Avoid prolonged exposure to high sound pressure levels. Wear hearing protection.
- Risk of hearing damage. Plugging or unplugging devices in the signal chain may cause an audio signal peak. Switch on the loudspeaker as the last device in the signal chain.
- Risk of hearing damage. Switching on or off other devices in the signal chain may cause an audio signal peak. Switch on the loudspeaker as the last device in the signal chain.

## 4.5

### ELECTRICAL SAFETY



- This is an electrical device in protection class I. Make sure that the protective conductor is connected to electrical earth. Do not disconnect the protective conductor.
- Do not bypass the mains fuse.
- Use only mains fuses as specified by the manufacturer.
- Do not use kinked or otherwise damaged power cables.
- Only operate the device on compliant, tested and intact mains power outlets.
- Do not use the device in the vicinity of water. Keep the device away from splashing or dripping water.

- Make sure that the voltage and frequency of the mains power match the values specified by the manufacturer.
- Take suitable measures against overvoltage, such as lightning strikes.
- For devices with a power out connector, make sure the total current consumption of all connected devices does not exceed the value specified by the manufacturer.
- This device is not suitable for continuous current.
- Disconnect the device from all poles before maintenance, repair or extend periods of non-use.
- Remove the batteries before repair or extend periods of non-use.
- Permanently connected power cables may only be replaced by a qualified service technician.

#### 4.6 PHYSICAL SAFETY



- Make sure that all mounting connections are adequately dimensioned. Observe the relevant regional safety guidelines when mounting the device.



- Make sure that the device and any accessories are securely positioned. Secure against unintentional movement.



- Check all load-bearing screw connections regularly and replace them if necessary.



- Check all cable routes to prevent tripping accidents.
- Moving components, such as mounting brackets, pose a risk of pinching injuries.

#### 4.7 THERMAL SAFETY

- Do not install the device near heat sources, such as radiators or ovens.
- Do not block any ventilation openings.
- Unless otherwise stated, keep a minimum clearance of at least 20 centimetres around the device.
- Unless otherwise stated, keep flammable materials, such as paper or wood, at least 50 centimetres away from the device

#### 4.8 WIRELESS SAFETY



Radio transmitter operation is subject to official regulations. Make sure you adhere to regional guidelines before commissioning.

Radio operation can lead to potentially dangerous effects. Do not use this device in sensitive areas such as:

- Hospitals, health centres or other healthcare facilities that provide patient treatment with skilled personnel and equipment
- Hazardous areas Class I, II and III
- Restricted areas
- Military facilities
- Areas where the use of mobile phones is prohibited, such as aircrafts.

Quality and performance of wireless signal transmissions is dependent on the environmental conditions. All range specifications refer to free-field application with visual contact without interference. Range and signal stability may be influenced by:



- Shielding, such as masonry, metal buildings, or water
- Interference
- High radio traffic, such as strong W-LAN networks
- Electromagnetic radiation, such as LED video walls or dimmers

## 4.9

### DEVICE SAFETY



**NOTICE**

#### Strong mechanical impacts

Damage to the wheels, the housing, and internal components.

- a. Do not drag the device over uneven surfaces such as cobblestones, or up and down stairs.

- Do not switch the device on and off in quick succession, because this will shorten the device lifetime.
- Loudspeakers generate a magnetic field, even when they are not in use. Devices, such as hard disk drives or cheque cards may be affected by the loudspeaker's magnetic field. Do not set up or transport these devices near the loudspeaker.

## 4.10

### BATTERY SAFETY

Risk of fire, explosion or outgassing. The following safety instructions must be observed.



- Find further information about the battery manufacturer as well as battery specifications in the device user manual.



- Keep the battery-powered device away from heat sources and do not expose it to direct sunlight or fire.



- Always observe the permissible ambient and operating conditions in the device user manual under Technical Data.

- Do not modify the battery and do not attempt to replace battery cells.
- Do not damage battery cells or battery packs. Do not use damaged battery cells or battery packs.
- Do not remove protective films from batteries or battery packs.
- Do not insert any foreign objects into the battery. Do not allow any liquids to enter the battery.
- If the device or the battery becomes deformed or overheats, switch it off immediately.
- Avoid strong mechanical impact on the battery and the device, such as dropping, smashing or puncturing as well as high pressure.
- Only charge the device or battery in the intended manner. Only use the original charger supplied by the manufacturer.
- In case of charging devices integrated in flight cases, leave the case lid open while charging.



- 
- Spilled liquids from batteries are corrosive, may be toxic, and can cause skin and eye irritations. Avoid any contact with spilled liquids from batteries. If you had contact with spilled liquids from batteries, wash the affected area immediately with plenty of water and consult a doctor.
  - Do not attempt to charge non-rechargeable batteries.
  - Do not short-circuit batteries and rechargeable batteries. Avoid contact between the battery terminals and electrically conductive objects, such as key rings or coins.
  - Ensure correct polarity when inserting batteries and rechargeable batteries. For correct polarity see the illustrations in the battery compartment or on the housing.
  - Do not use different cell types and battery brands in one device at the same time.
  - Only use batteries and rechargeable batteries with the same discharge status.

### **CHARGING, OPERATING, AND STORING BATTERIES**

- Devices with lithium batteries are equipped with the usual protective devices.
- The charging time for a full charge of the battery can be found in the device user manual under Technical Data.
- Do not charge, operate, or store the battery outside the ambient conditions specified in the device user manual under Technical Data.
- Fully recharge the battery as soon as possible after discharging.
- Only store the device with a fully charged battery. Batteries that are not fully charged can lose capacity and service life prematurely.
- If the device is not used for a longer period of time, carry out a complete discharge and charge cycle at least every 3 months.
- The main power switch must be switched off during storage.
- Specified battery runtimes always refer to a new battery under normal operating conditions.
- When operating in a cold environment, the battery life may be shorter than specified.

## 5 PRODUCT DESCRIPTION

### 5.1 PRODUCT OVERVIEW

#### FEATURES

- Portable and battery-powered all-in-one audio solution
- Integrated 6-channel mixer with system presets, 3-band EQ and effects (Reverb & Delay)
- DynX® DSP (Gen.2) for distortion-free sound even at maximum volume
- Two receiver slots for wireless microphones or bodypacks
- Two switchable mic or line inputs
- Up to 5 hours battery life at maximum volume, 20 hours at moderate volume
- Priority/ducking mode to highlight microphone signal
- Built-in wheels and retractable handle
- 35 mm flange for applications on a speaker pole
- AAC coding for HD Bluetooth® 5.0 streaming
- True Wireless Stereo (TWS) to connect two ANNYS
- USB-C port for charging your mobile devices
- Integrated holder for tablet or phone
- Footswitch input for hands-free control of effects

### 5.2 PRODUCT VARIANTS

The LD Anny® Series offers the following product variants.

#### LD ANNY® 8 STAGE BLACK

- **LDANNY8** - Portable battery-powered Bluetooth® PA loudspeaker with mixer, 8" woofer, and a 1" tweeter
- **LDANNY8HHD** - Portable battery-powered Bluetooth® PA loudspeaker with mixer, 8" woofer, 1" tweeter, hand-held transmitter, receiver module+antenna
- **LDANNY8BPH** - Portable battery-powered Bluetooth® PA loudspeaker with mixer, 8" woofer, 1" tweeter, pocket transmitter+headset, receiver module

#### LD ANNY® 8 PURE WHITE

- **LDANNYW8** - Portable battery-powered Bluetooth® PA loudspeaker with mixer, 8" woofer, and a 1" tweeter
- **LDANNYW8HHD** - Portable battery-powered Bluetooth® PA loudspeaker with mixer, 8" woofer, 1" tweeter, handheld transmitter, receiver module+antenna
- **LDANNYW8BPH** - Portable battery-powered Bluetooth® PA loudspeaker with mixer, 8" woofer, 1" tweeter, pocket transmitter+headset, receiver module

**LD ANNY® 8 URBAN GREY**

- **LDANNYBG8** - Portable battery-powered Bluetooth® PA loudspeaker with mixer, 8" woofer, and a 1" tweeter
- **LDANNYBG8HHD** - Portable battery-powered Bluetooth® PA loudspeaker with mixer, 8" woofer, 1" tweeter, handheld transmitter, receiver module+antenna
- **LDANNYBG8BPH** - Portable battery-powered Bluetooth® PA loudspeaker with mixer, 8" woofer, 1" tweeter, pocket transmitter+headset, receiver module

**LD ANNY® 8 ADVENTURE GREEN**

- **LDANNYGN8** - Portable battery-powered Bluetooth® PA loudspeaker with mixer, 8" woofer, and a 1" tweeter
- **LDANNYGN8HHD** - Portable battery-powered Bluetooth® PA loudspeaker with mixer, 8" woofer, 1" tweeter, handheld transmitter, receiver module+antenna
- **LDANNYGN8BPH** - Portable battery-powered Bluetooth® PA loudspeaker with mixer, 8" woofer, 1" tweeter, pocket transmitter+headset, receiver module

**LD ANNY®10**

- **LDANNY10** - Portable battery-powered Bluetooth® PA loudspeaker with mixer, 10" woofer, 1" tweeter, wheels, and telescopic handle
- **LDANNY10HHD** - Portable battery-powered Bluetooth® PA loudspeaker with mixer, 10" woofer, 1" tweeter, handheld transmitter, receiver module+antenna, wheels, and telescopic handle
- **LDANNY10HHD2** - Portable battery-powered Bluetooth® PA loudspeaker with mixer, 10" woofer, 1" tweeter, 2x handheld transmitter, 2x receiver module, wheels, and telescopic handle
- **LDANNY10BPH** - Portable battery-powered Bluetooth® PA loudspeaker with mixer, 10" woofer, 1" tweeter, body pack transmitter+headset, receiver module+antenna, wheels, and telescopic handle
- **LDANNY10BPH2** - Portable battery-powered Bluetooth® PA loudspeaker with mixer, 10" woofer, 1" tweeter, 2x bodypack transmitter, 2x receiver module+antenna, wheels, and telescopic handle
- **LDANNY10HBH2** - Portable battery-powered Bluetooth® PA loudspeaker with mixer, 10" woofer, 1" tweeter, handheld transmitter, body pack transmitter+headset, 2x receiver module, wheels, and telescopic handle

**LD ANNY®12**

- **LDANNY12** - Portable battery-powered Bluetooth® PA loudspeaker with mixer, 12" woofer, 1.4" tweeter, wheels, and telescopic handle
- **LDANNY12HHD** - Portable battery-powered Bluetooth® PA loudspeaker with mixer, 12" woofer, 1.4" tweeter, handheld transmitter, receiver module+antenna, wheels, and telescopic handle
- **LDANNY12HHD2** - Portable battery-powered Bluetooth® PA loudspeaker with mixer, 12" woofer, 1.4" tweeter, 2x handheld transmitter, 2x receiver module, wheels, and telescopic handle
- **LDANNY12BPH** - Portable battery-powered Bluetooth® PA loudspeaker with mixer, 12" woofer, 1.4" tweeter, body pack transmitter+headset, receiver module+antenna, wheels, and telescopic handle

- **LDANNY12BPH2** - Portable battery-powered Bluetooth® PA loudspeaker with mixer, 12" woofer, 1.4" tweeter, 2x bodypack transmitter, 2x receiver module+antenna, wheels, and telescopic handle
- **LDANNY10HBH2** - Portable battery-powered Bluetooth® PA loudspeaker with mixer, 12" woofer, 1.4" tweeter, handheld transmitter, body pack transmitter+headset, 2x receiver module, wheels, and telescopic handle

### 5.3 OPTIONAL ACCESSORIES

Accessory	Frequency range	Item number
Receiver Module for ANNY®	823 – 832 MHz + 863 – 865 MHz	LDANNYRB8
Receiver Module for ANNY®	655 – 679 MHz	LDANNYRB6
Receiver Module for ANNY®	584 – 608 MHz	LDANNYRB5
Handheld Microphone for ANNY®	823 – 832 MHz + 863 – 865 MHz	LDANNYMDB8
Handheld Microphone for ANNY®	655 – 679 MHz	LDANNYMDB6
Handheld Microphone for ANNY®	584 – 608 MHz	LDANNYMDB5
Bodypack Transmitter for ANNY®	823 – 832 MHz + 863 – 865 MHz	LDANNYBPB8
Bodypack Transmitter for ANNY®	655 – 679 MHz	LDANNYBPB6
Bodypack Transmitter for ANNY®	584 – 608 MHz	LDANNYBPB5

#### ONLY FOR US MARKET

Accessory	Frequency range	Item number
Receiver Module for ANNY®	514 – 542 MHz	LDANNYRB51
Receiver Module for ANNY®	470 – 490 MHz	LDANNYRB47
Handheld Microphone for ANNY®	514 – 542 MHz	LDANNYMDB51
Handheld Microphone for ANNY®	470 – 490 MHz	LDANNYMDB47
Bodypack Transmitter for ANNY®	514 – 542 MHz	LDANNYBPB51
Bodypack Transmitter for ANNY®	470 – 490 MHz	LDANNYBPB47

Accessory	Item number
Protective weather cover for portable use of ANNY® 12	LDANNY12PC

### 5.4 DIMENSIONS

Visit the download centre to download the product dimensions as a CAD file.

## 5.5 TECHNICAL DATA

### GENERAL

Parameter	Value
Product type	Battery-powered PA active speaker
Housing colour	Black
System output	185 W
System output (Peak)	215 W
Max SPL (Average)	116 dB (Fullspace)
Max SPL (Peak)	122 dB (Fullspace)
Frequency response (-10 dB)	40 Hz ... 20 kHz
Crossover frequency	1600 Hz
Dispersion (H x D)	90° x 50°
Width	405 mm
Depth	341 mm
Height	655 mm
Features	TWS, 6-channel mixer with system presets, 3-band EQ, effects (reverb & delay), priority/ducking mode, USB-C port für mobile device charging
Weight	18.925 kg

### LOW/MID WOOFER

Parameter	Value
Low/mid woofer size (inch)	12"
Low/mid woofer size (mm)	305 mm
Woofer magnet	Neodymium
Woofer brand	Custom made
Woofer voice coil (inch)	2"
Woofer voice coil (mm)	36 mm
Cabinet design	Bass Reflex
Housing material	Acrylonitrile Butadiene Styrene (ABS)

### HIGH FREQUENCY (HF)

Parameter	Value
Horn type	Constant directivity

Parameter	Value
Tweeter size (inch)	1.4"
Tweeter size (mm)	36 mm
Tweeter magnet	Ferrite
Tweeter brand	Custom made
Tweeter voice coil (inch)	1.4"
Tweeter voice coil (mm)	36 mm

### AMPLIFIER MODULE (INTEGRATED)

Parameter	Value
Amplifier	Class D
Protective circuits	Short Circuit, Overtemperature
Ambient temperature (operating)	0°C ... 40°C
Relative humidity	0 % ... 80 %, non-condensing
Fuse	T3.15AL 250V
Control elements	Main Volume/Menu Navigation, Input 1 Volume, Input 1 Mic/Line Switch, Input 2 Volume, Input 2 Mic/Line Switch, Input 3+4 Volume, Bluetooth Volume, Effect, Power
Indicators	Battery status, multifunctional LC display
Power connector	IEC
Operation voltage	100 V ... 240 V, 50 Hz ... 60 Hz
Power consumption	250 W
Number of inputs	5
Input connectors	2x 6.3 mm/XLR combo, 2x RCA, 3.5 mm jack
Number of outputs	1
Output connectors	XLR male
Bluetooth® standard	5.0
Bluetooth® audio decoder	SBC/AAC

### BATTERY

Parameter	Value
Rated voltage	14.4 V/ 5000 mAh
Battery technology	Li Ion

Parameter	Value
Indicators (Battery)	4-segment LED
Battery operation time music (Music preset, full volume)	1.25 h (one Battery), 5 h (4 Batteries)
Battery operation time music (Eco preset, full volume)	3.5 h (one Battery), 14 h (4 Batteries)
Battery operation time music (Music preset, mid-volume)	10.5 h (one Battery), 42 h (4 Batteries)
Battery operation time music (Eco preset, mid-volume)	12.5 h (one Battery), 50 h (4 Batteries)
Charging time (full recharge, no signal)	3 h
Charging time (80%, no signal)	2 h

### WIRELESS RECEIVER

Parameter	Value
Transmission frequency range	470 MHz ... 490 MHz (USA version), 512 - 542 MHz (USA version), 584 - 608 MHz, 655 - 679 MHz, 823 - 832 MHz + 863 - 865 MHz
Modulation type	FM
Number of channels	12
Frequency response	50 Hz ... 17000 Hz
Controls	SYNC, Mute Level (Squelch), Power / Volume, Value Down, Value Up
Indicators	AF (LED), LED Display, RF (LED)
Connections	BNC for receiver antenna, Audio out

**5.6 USER INTERFACE OVERVIEW**

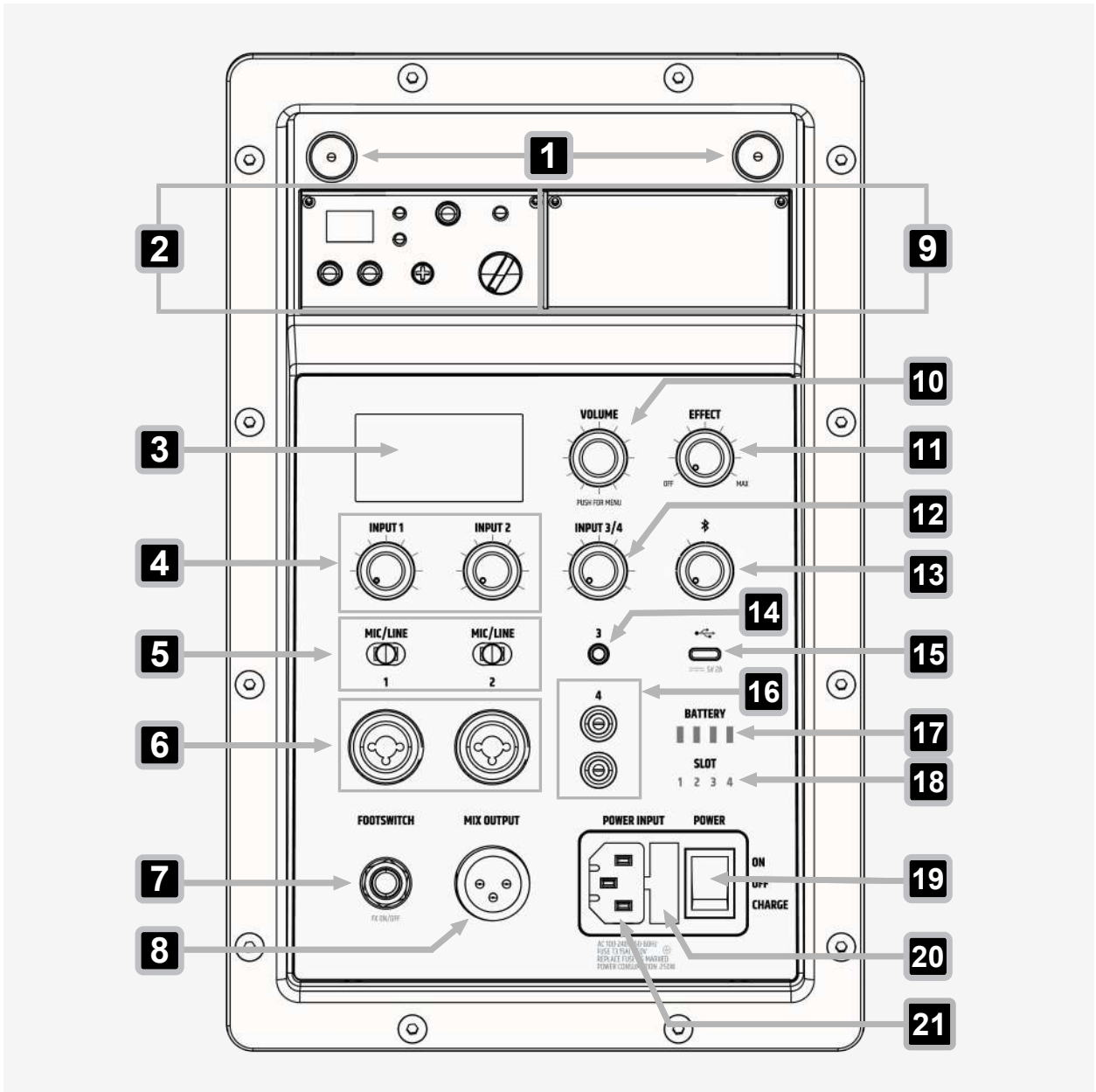

- 1** **ANTENNA BNC Sockets** - Connect antennas to the receiver modules
- 2** **Receiver Module Unit** - Receives signals from handheld transmitter or bodypack transmitter via an infrared interface.
- 3** **LC Display** - Main graphic display
- 4** **INPUT 1 & 2 Rotary-Push Encoders (RPES)** - Control the volumes for channels 1 and 2
- 5** **MIC/LINE Slide Switches** - Switches between MIC and LINE
- 6** **Input 1 & 2 Combo Sockets** - Balanced XLR / 6.35 mm jack combo sockets for mic or line connections



- 7** **FOOTSWITCH Socket** - Mutes and unmutes the internal effect module or the MAIN channel (6.3 mm TRS jack)
- 8** **MIX OUT** - Audio output socket (balanced 3-pin XLR)
- 9** **INPUT 6 Placeholder Cover** - Serves as a placeholder for a receiver module for channel 6.
- 10** **VOLUME Rotary-Push Encoder (RPE)** - Controls the main volume and browses through the menu pages. Hold for 1 second to access the settings.
- 11** **EFFECT Rotary Encoder** - Adjusts the effect volume (effect return)
- 12** **INPUT 3/4 Rotary Encoder** - Controls the volume of channels 3 and 4
- 13** **Bluetooth® Rotary-Push Encoder** - Controls the volume of the Bluetooth® channel
- 14** **Input 3** - Unbalanced stereo line input with 3.5 mm jack socket
- 15** **USB-C** - Charges a smartphone or tablet (5 volts voltage, maximum 2 A charging current)
- 16** **Input 4** - Unbalanced stereo line input with two RCA sockets
- 17** **BATTERY** - Displays the battery charge status
- 18** **SLOT** - Indicates the names of the battery slots left to right
- 19** **POWER** - Switches the device on, off, or into charge mode.
- 20** **Fuse Compartment** - Contains the main fuse
- 21** **POWER INPUT** - Device power socket with integrated fuse holder

## 6 PREPARATION

### 6.1 SCOPE OF DELIVERY

- Device
- Mains power cable
- Safety Compliance Information
- Quick Start Guide

### 6.2 TRANSPORT

---



**NOTICE**

#### **Improper device transport handling**

Risk of damage to the device

- a. Turn the device off
  - b. Remove all cables
  - c. Do not roll the device over rough or uneven surfaces
  - d. Do not roll the device over stairs
  - e. Use the handles to carry the device if the terrain is unsuitable for rolling.
-

## 6.2.1 TRANSPORT HANDLE OVERVIEW

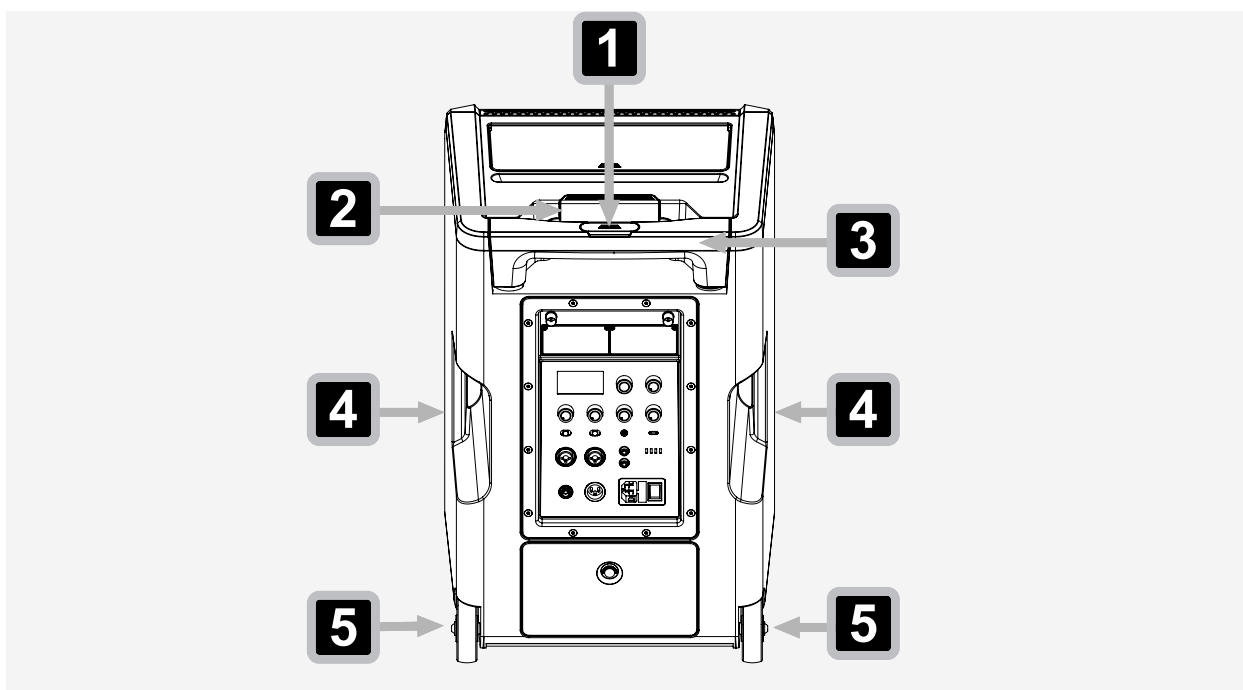

- 1** Release button
- 2** Top handle
- 3** Telescopic handle
- 4** Side handles
- 5** Castor wheels

## 6.2.2 PULLING OUT THE HANDLE

- 1** Press and hold the **release button**
- 2** Pull out the handle from the speaker housing until it reaches its limit.
- 3** Release the **release button**.

## 6.2.3 PUSHING IN THE HANDLE

- 1** Press and hold the **release button**.
- 2** Push the handle back into the housing until it reaches its limit.
- 3** Release the **release button**.

## 6.3 USING THE MOBILE DEVICE TRAY AND ACCESSORY COMPARTMENT



Store handheld transmitters and bodypack transmitters, or any accessory in the accessory compartment.

### OPENING THE ACCESSORY COMPARTMENT

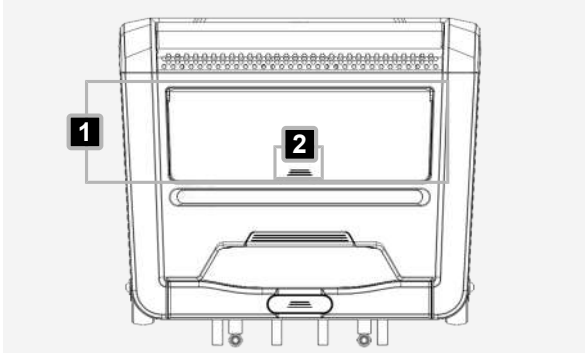

- 1 Push the **release mechanism** **2** to unlock the accessory compartment lid **1**.
- 2 Open the accessory compartment.

### CLOSING THE ACCESSORY COMPARTMENT

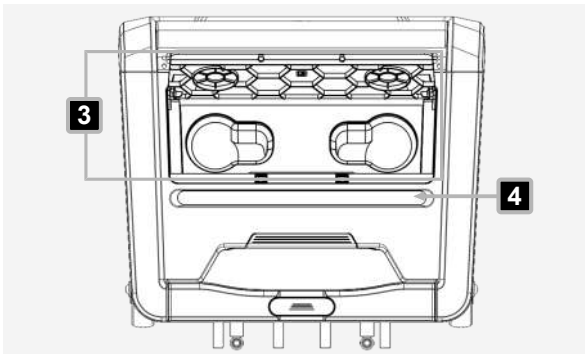

- 3 Lower the accessory compartment lid **3**.
- 4 Push the accessory compartment lid down until the **release mechanism** clicks into place.



The mobile device tray **4** is designed to hold a mobile device

## 7 INSTALLATION

### 7.1 MOUNTING THE ANNY® 12 ON A STAND OR A SPEAKER POLE



**WARNING**

#### **Falling object**

Risk of serious injury

- a. Observe all regional safety regulations concerning overhead loads.
- b. Use only stands or speaker poles with a suitable tube diameter.
- c. Make sure that the stand or speaker pole supports the weight of the device.
- d. Make sure that the stand or the device with attached speaker pole is securely positioned on a level surface.

✓ You have securely set up an appropriate stand or a speaker pole with a tube diameter of 35 mm.

- 1 Lift and place the Anny®12 onto the flange position.



For lifting the Anny® 12, use the top handle or the side handles.

## 8 OPERATION

### 8.1 POWER SUPPLY

#### 8.1.1 CONNECTING A MAINS POWER CABLE



**WARNING**

##### Mains voltage

Risk of electric shock

- a. Do not use kinked or damaged mains power cables



**NOTICE**



##### Damage to the Device

- a. Make sure that the voltage of the mains power socket matches the device operating voltage.
- b. Use the supplied mains power cable.
- c. Do not plug or unplug the device under load.
- d. Power off the device before connecting or disconnecting the mains power cable.

- 1 Plug the C13 connector of the mains power cable into the C14 socket on the device. Make sure the connector is positioned correctly.
- 2 Plug the power connector of the mains power cable into the mains power socket.

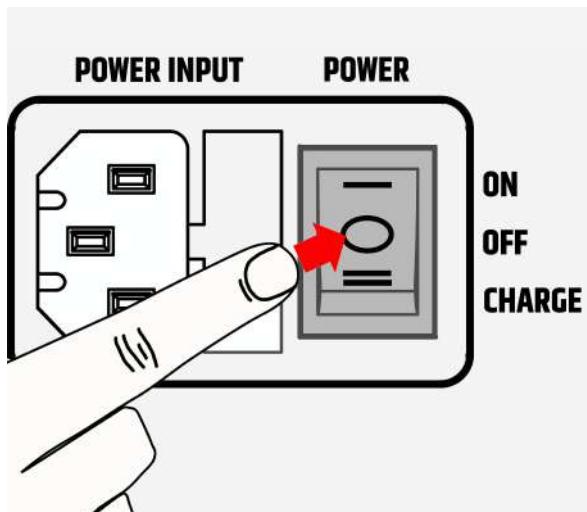
#### 8.1.2 USING THE ON / OFF / CHARGE SWITCH



- 1 Flip the switch to the  position.
  - ⇒ The display turns on and the device boots.
  - ⇒ After a few seconds, the device is operational.
  - ⇒ The battery charging function is activated.
- 2 Flip the switch to the  position.
  - ⇒ The device turns off.
  - ⇒ The battery charging function is deactivated.
- 3 Flip the switch to the  position.
  - ⇒ The device turns off.
  - ⇒ The battery charging function is activated.

#### 8.1.3 DISCONNECTING THE MAINS POWER CABLE

✓ You have disconnected the device from the mains.

- 1 Pull the device power connector out of the socket.

## 8.2 NAVIGATING THE DEVICE

### 8.2.1 USING THE ROTARY-PUSH ENCODER

You can use the **VOLUME rotary-push encoder (RPE)** to access all submenu items and adjust settings.

- 1 Push the **VOLUME RPE** to enter the menu.
- 2 Turn the **VOLUME RPE** clockwise or anticlockwise till the corresponding submenu item is highlighted.
- 3 Push the **VOLUME RPE** to enter the highlighted submenu.
- 4 Turn the **VOLUME RPE** to adjust the values of the submenu item.
- 5 Push the **VOLUME RPE** to validate the input and exit the submenu.



The return option  takes you one level up in the menu.

After 10 seconds of inactivity, the display automatically switches back to the main display.

### 8.2.2 ACCESSING THE SETTINGS SECTION

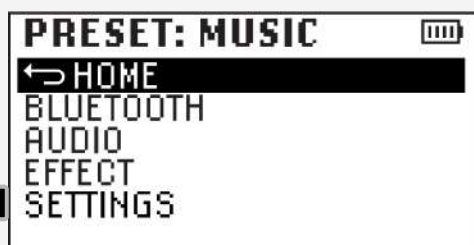

- 1 Push the **VOLUME rotary-push encoder (RPE)** to access the main menu.
- 2 Turn the **VOLUME RPE** clockwise until the corresponding menu item is highlighted.
- 3 Push the **VOLUME RPE** to access the corresponding sub menu.

## 8.3 DEVICE DISPLAY OVERVIEWS

### 8.3.1 MAIN SCREEN OVERVIEW

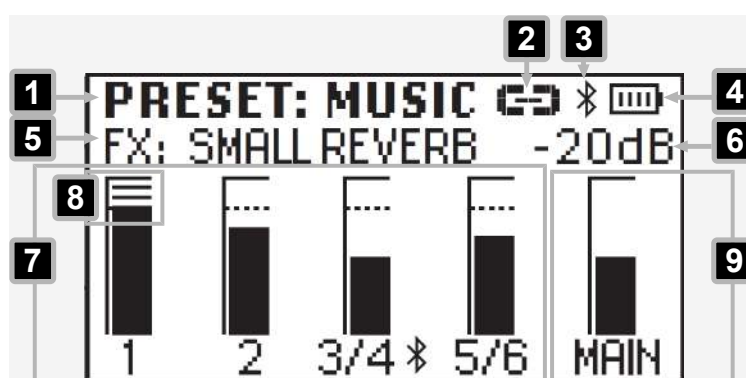

- 1 **PRESET** - Indicates the selected preset
- 2
  - **TWS Symbol** - Indicates that the TWS mode is active
  - **TWS Symbol is flashing** - Indicates that TWS is active and ready for coupling
  - **TWS Symbol is missing** - Indicates that TWS is deactive

- 3** • **Bluetooth® Symbol** - Indicates that the Bluetooth® mode is active
- **Bluetooth® Symbol is flashing**- Indicates that the Bluetooth® mode is active and ready for pairing
- **Bluetooth® Symbol is missing**- Indicates that the Bluetooth® mode is deactive
- 4** **Battery Symbol** - Indicates the battery charge status
- 5** **FX:** - indicates the selected effect preset
- 6** **dB Display** - Indicates the decibel value of the main channel
- 7** **Channel Volume** - Indicates the signal levels and signal peaks of the channels
- 8** **Peak Indicator** - Indicates that the channel input level is above the distortion limit.
- 9** **MAIN Volume** - Indicates the signal level of the main channel

 To avoid distortion, reduce the output level of the connected playback device (e.g. mixer, keyboard, etc).

8.3.1.1 **BLUETOOTH® SETTING OVERVIEW**



- 1** ← **MAIN MENU** - Returns to the previous section
- 2** **BLUETOOTH** - Switches Bluetooth® on or off
- 3** **TWS** - Switches True Wireless Stereo (TWS) on or off



## 8.3.1.2 AUDIO SETTINGS OVERVIEW



- 1** ← **MAIN MENU** - Returns to the previous section
- 2** **PRESET** - Selects the preset (**MUSIC, VOCAL, LIVE, ECO, OFF**)
- 3** **HIGH EQ** - Adjusts treble frequencies from -12 dB ... + 12 dB
- 4** **MID EQ** - Adjusts mid frequencies from -12 dB ... + 12 dB
- 5** **LOW EQ** - Adjusts bass frequencies from -12 dB ... + 12 dB
- 6** **DELAY** - Adjusts the delay of the sum signal in 0.5m steps from 0 m ...10 m (0 m/0 ft=no delay)
- 7** **PRIORITY** - Prioritises the selected channel (INPUT 1, 2, or 5/6) and dims other signals while the prioritized channel signal is active.



If the prioritised signal is no longer present, the volume of the other channels will return to their original levels after a few seconds



It's not possible to make multiple selections for prioritisation

## 8.3.1.3 EFFECTS MENU OVERVIEW



- 1** ↩ MAIN MENU - Returns to the previous section
- 2** FX TYPE - Selects the effect type (**SMALL REVERB**, **LARGE REVERB**, **PLATE REVERB**, **DELAY**, **OFF**)
- 3** FX SENDS - Sets the effect sends for the selected channel (INPUT 1, 2, and 5/6) from 0 % ... 100 %

## 8.3.1.4 SYSTEM SETTING OVERVIEW



- 1** ↩ MAIN MENU - Returns to the previous section
- 2** LCD DIM - Toggles the dimming function for the LCD display on or off (on: the display illumination stays on for approximately 10 seconds, then turns off)
- 3** BRIGHTNESS - Adjusts the display brightness from 0 % ... 100 %
- 4** CONTRAST - Adjusts the display contrast from 0 % ... 100 %
- 5** INFO - Displays the device model name and the current software version
- 6** FACTORY DEFAULT - Resets the device to factory settings

## 8.4 TRUE WIRELESS STEREO (TWS)

### 8.4.1 ABOUT TRUE WIRELESS STEREO (TWS)

True Wireless Stereo (TWS) is a Bluetooth®-based technology. It is used to connect wireless audio devices with each other providing high sound quality and stereo playback capabilities.



Only audio signals played on a paired Bluetooth® playback device can be transmitted via the stereo link function (TWS). Audio signals from physical inputs are not transmitted via TWS.

## 8.5 INPUT CONNECTIONS

### 8.5.1 CONNECTING AN INPUT SOURCE TO THE MIC / LINE INPUT



**WARNING**

#### High sound pressure levels

Risk of hearing damage

- a. Make sure that the main volume is turned all the way down, before you connect any input sources.



**NOTICE**

#### High Sound Pressure Level

Damage to the loudspeaker

- a. Connect line level devices, such as mixing consoles, to the line input only.

- 1 Toggle the **MIC/LINE** select button to the corresponding input type.
- 2 Connect a microphone input or a line input source to the **INPUT 1** or **INPUT 2** combo socket.

### 8.5.2 BLUETOOTH® FOR AUDIO PLAYBACK MONO MODE



**WARNING**

#### High sound pressure levels

Risk of hearing damage

- a. Make sure that the main volume is turned all the way down, before you connect any input sources.



**NOTICE**

#### High Sound Pressure Level

Damage to the loudspeaker

- a. Connect line level devices, such as mixing consoles, to the line input only.



**8.5.2.1 PAIRING A MOBILE DEVICE VIA BLUETOOTH® FOR AUDIO PLAYBACK**



- 1 Push the **VOLUME rotary-push encoder (RPE)** to enter the main menu.
- 2 Turn the **VOLUME RPE** until **BLUETOOTH** is highlighted **1**.
- 3 Push the **VOLUME RPE** to enter the Bluetooth® submenu.



- 4 Turn the **VOLUME RPE** until **BLUETOOTH OFF** is highlighted **2**.



- 5 Turn the **VOLUME RPE** to choose **PAIRING 3**
- 6 Push the **VOLUME RPE**.  
⇒ The Bluetooth symbol **4** flashes while the device is available for pairing.

- 7 Activate Bluetooth® on your mobile device, such as smartphone or tablet.
- 8 Choose **ANNY 12** in the Bluetooth® menu of your playback device, to start the pairing process.  
⇒ After a successful pairing process, the Bluetooth® icon appears in the main display **4**.

**8.5.2.2 UNPAIRING A BLUETOOTH® DEVICE**



- 1 Push the **VOLUME rotary-push encoder (RPE)** to enter the main menu.
- 2 Turn the **VOLUME RPE** until **BLUETOOTH** is highlighted **1**.
- 3 Push the **VOLUME RPE** to enter the Bluetooth® submenu.



4 Turn the **VOLUME RPE** until **BLUETOOTH PAIRED** is highlighted **2**.

5 Push the **VOLUME RPE**.



6 Turn the **VOLUME RPE** to choose **OFF** **3**

7 Push the **VOLUME RPE** to deactivate the Bluetooth® mode.

⇒ The Bluetooth® icon disappears from the main display **4**.

### 8.5.3 BLUETOOTH® FOR AUDIO PLAYBACK STEREO MODE



#### 8.5.3.1 LINKING TWO ANNY® 12 DEVICES VIA TRUE WIRELESS STEREO (TWS)

- ✓ You have two ANNY® 12 devices available that you've turned on.
- ✓ You have connected one ANNY® 12 via Bluetooth® to a playback device.

#### TWS MODE MAIN UNIT – BLUETOOTH-CONNECTED DEVICE



1 Push the **VOLUME rotary-push encoder (RPE)** to enter the main menu.

2 Turn the **VOLUME RPE** until **BLUETOOTH** is highlighted **1**.

3 Push the **VOLUME RPE** to enter the Bluetooth® submenu.



- 4 Turn the **VOLUME RPE** until **TWS OFF** is highlighted **2**.
- 5 Push the **VOLUME RPE** to enter the TWS sub-menu.



- 6 Turn the **VOLUME RPE** to choose **LINK 3**.
- 7 Push the **VOLUME RPE** to activate the TWS mode.
  - ⇒ The TWS icon on the display starts flashing.

**TWS MODE FOLLOWER UNIT**



- 8 Push the **VOLUME RPE** to enter the main menu.
- 9 Turn the **VOLUME RPE** until **BLUETOOTH** is highlighted **4**.
- 10 Push the **VOLUME RPE** to enter the Bluetooth® sub-menu.



- 11 Turn the **VOLUME RPE** until **TWS OFF** is highlighted **5**.
- 12 Push the **VOLUME RPE** to enter the TWS sub-menu.



- 13 Turn the **VOLUME RPE** to choose **LINK 6**.
- 14 Push the **VOLUME RPE** to activate the TWS mode.

- ⇒ After a successful TWS pairing, the TWS icon stops flashing and is shown on both device displays.
- ⇒ The **ANNY® 12** connected via Bluetooth® to a playback device becomes the main unit (stereo right).
- ⇒ The **ANNY® 12** stereo extension becomes the follower unit (stereo left).

 After restarting the **ANNY® 12** speakers Bluetooth® reconnects automatically, while TWS remains deactivated.

## 8.5.4 UNLINKING TWS CONNECTION

✓ You have two ANNY® 12 devices connected via TWS.

- 1 Push the **VOLUME rotary-push encoder (RPE)** to enter the main menu.
- 2 Turn the **VOLUME RPE** until **TWS** is highlighted.
- 3 Push the **VOLUME RPE** to enter the **TWS** submenu.

### FOR MAIN UNIT – BLUETOOTH-CONNECTED DEVICE:

- 4 Turn the **VOLUME RPE** until **TWS LINK** is highlighted.

### FOR FOLLOWER UNIT:

- 5 Turn the **VOLUME RPE** until **TWS LINKED** is highlighted.
- 6 Push the **VOLUME RPE** to enter the TWS submenu.
- 7 Turn the **VOLUME RPE** to choose **OFF**.
- 8 Push the **VOLUME RPE** to deactivate the TWS mode.

## 8.6 AUDIO PLAYBACK

### 8.6.1 ADJUSTING THE MAIN VOLUME



- 1 Turn the **VOLUME rotary-push encoder (RPE)** clockwise to increase the main volume.
- 2 Turn the **VOLUME RPE** anticlockwise to decrease it.

### 8.6.2 ADJUSTING THE CHANNEL VOLUME

- 1 Turn the channel **rotary-push encoder (RPE)** clockwise to increase the channel volume.
- 2 Turn the channel **RPE** anticlockwise to decrease it.

### 8.6.3 USING THE FOOTSWITCH

- 1 Connect the 6.3 mm footswitch jack to the **FOOTSWITCH** socket.
- 2 Push the footswitch to toggle the effects on or off.

## 8.7 RF CONNECTIONS

### 8.7.1 RECEIVER MODULE

#### 8.7.1.1 ABOUT RECEIVER MODULES

##### **ANNY® 12 WITH RECEIVER MODULE**

The receiver module receives signals via an infrared interface. It captures signals from either a handheld transmitter or a bodypack transmitter.

##### **ANNY® 12 WITHOUT RECEIVER MODULE**

The device may be retrofitted with a receiver module by an authorized service partner.



**DANGER**

##### **Mains Voltage**

Risk of a electric shock

- a. Do not open the device.



**NOTICE**

##### **Incorrectly mounted receiver module**

Risk of damage to the device

Void of warranty

- a. Do not modify the device yourself.
  - b. Contact Adam Hall Customer Service to request retrofitting of a receiver module.
-



## 8.7.1.2 RECEIVER MODULE OVERVIEW

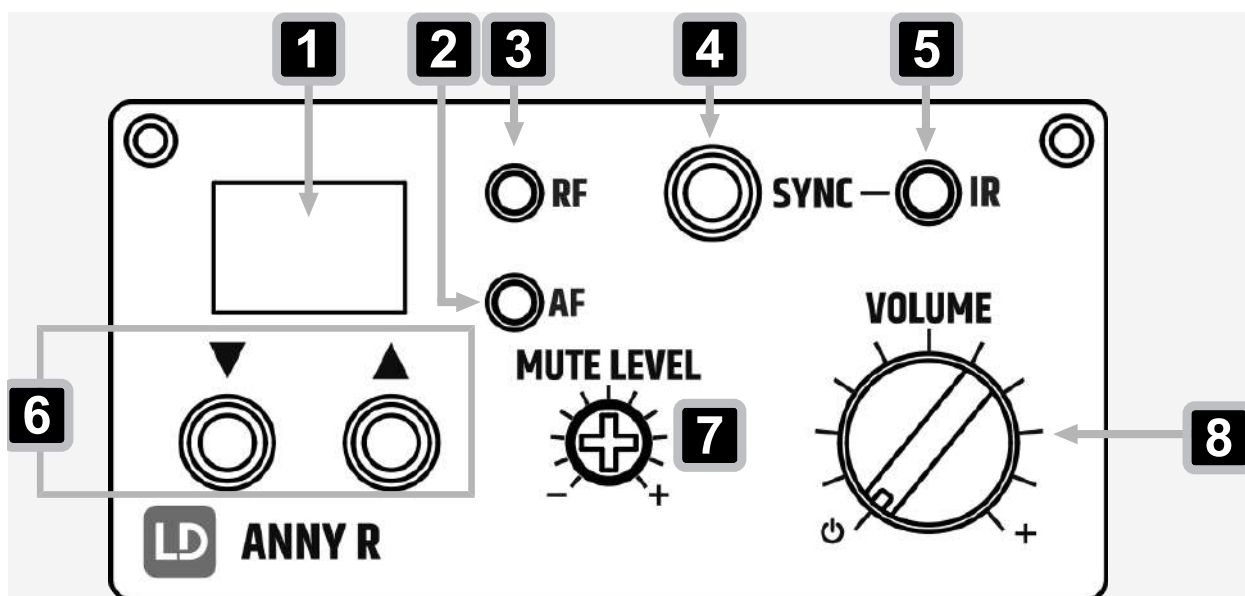

- 1** **LED DISPLAY** - Displays the selected radio channel (channel 01 ... 12).
- 2** **Green AF LED** - Indicates a present audio signal.
- 3** **Red RF LED** - Indicates a present connection between the transmitter and the receiver
- 4** **SYNC** - Starts the synchronisation process.
- 5** **IR** - Syncs transmitters to the receiver.
- 6** **▼ ▲ buttons** - Select the radio channels.
- 7** **MUTE LEVEL** - Sets the threshold level of the squelch – lower signals (like the RF noise floor) are muted
- 8** **VOLUME** - Turns on the receiver and adjusts the volume of the connected transmitter.

## 8.7.1.3 TURNING THE RECEIVER MODULE ON OR OFF

- 1** Turn the receiver module **VOLUME encoder** clockwise past the detent to switch on.
- 2** Turn the receiver module **VOLUME encoder** counterclockwise past the detent to switch off.

## 8.7.1.4 ADJUSTING THE RECEIVER VOLUME

- 1** Turn the receiver module **VOLUME encoder** clockwise to increase the receiver volume.
- 2** Turn the receiver module **VOLUME encoder** anticlockwise to decrease the receiver volume.

## 8.7.1.5 ABOUT MUTE LEVEL

The mute level function prevents:

- **Interference noise** when the transmitter is turned off.

- **Sudden interference noise** if the signal transmitted to the receiver is not strong enough (e.g., due to excessive distance between the transmitter and receiver).

 The mute level control is set to minimum noise suppression by default. This setting is suitable for most applications, with changes rarely needed..

**8.7.1.6 ADJUSTING THE RECEIVER MODULE MUTE LEVEL**

- ✓ You have decreased the speaker volume to a minimum
- ✓ You have switched off the transmitter
- ✓ A suitable Phillips screwdriver

**INCREASING THE NOISE SUPPRESSION**

- 1 Turn the **MUTE LEVEL** screw clockwise.

**DECREASING THE NOISE SUPPRESSION**

- 2 Turn the **MUTE LEVEL** screw anticlockwise.
  - ⇒ You have correctly set the mute level when background noise is just effectively suppressed.

**8.7.2 TRANSMITTERS**

**8.7.2.1 HANDHELD TRANSMITTER OVERVIEW**

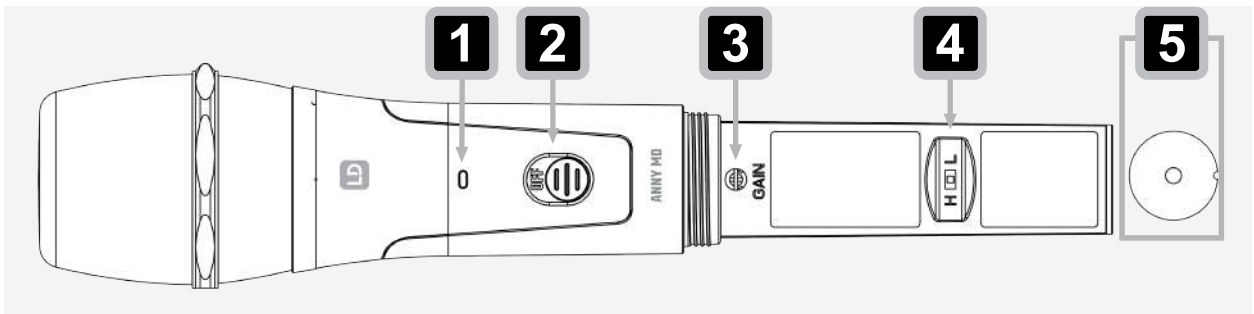

- 1** **Status LED** - Green indicates that the charging status of the inserted batteries is sufficient. Red indicates that the battery charge is low and the batteries need to be replaced immediately
- 2** **ON / OFF** - Switches the handheld transmitter on or off
- 3** **GAIN** - Adjusts the sensitivity of the input signal.
- 4** **HF-Switch** - Toggles between high (**H**) and low (**L**) frequency settings
- 5** **Infrared Interface** - Synchronises the radio channels between the receiver and transmitter.

### 8.7.2.11 ADJUSTING THE INPUT SENSITIVITY OF THE HANDHELD TRANSMITTER

- 1 Turn the **GAIN** screw anticlockwise to decrease the input sensitivity.
- 2 Turn the **GAIN** screw clockwise to increase the input sensitivity.

### 8.7.2.12 REPLACING THE BATTERIES OF THE HANDHELD TRANSMITTER

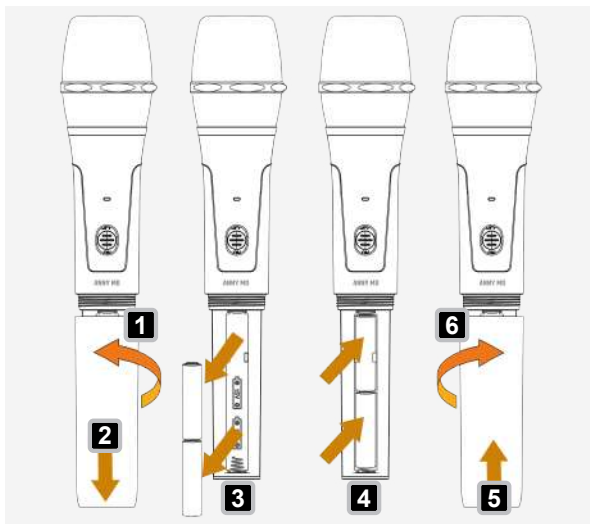

- 1 Screw the battery compartment cover counter-clockwise **1**.
- 2 Pull the cover off the battery compartment **2**.
- 3 Remove the used batteries **3**.
- 4 Insert fresh batteries **4**.

**i** The handheld transmitter is powered by 2 AA (LR6) alkaline batteries.

- 5 Slide the battery compartment cover onto the battery compartment **5**.
- 6 Screw the battery compartment cover clockwise to lock it **6**.



If you are not using the handheld transmitter for a long period, remove the batteries to prevent damage from leaks.

### 8.7.2.13 SYNCING A HANDHELD TRANSMITTER TO A RECEIVER

- 1 Select a radio channel on the receiver.
- 2 Switch on the handheld transmitter.
- 3 Press the **SYNC** button while pointing the infrared interface of the handheld transmitter in direct visual contact with the infrared interface of the receiver.



The infrared interface of the hand-held transmitter is located on the underside of the handheld transmitter.

⇒ After successful synchronisation, the red **RF** indicator LED on the receiver module lights up.

8.7.2.2 BODYPACK TRANSMITTER OVERVIEW

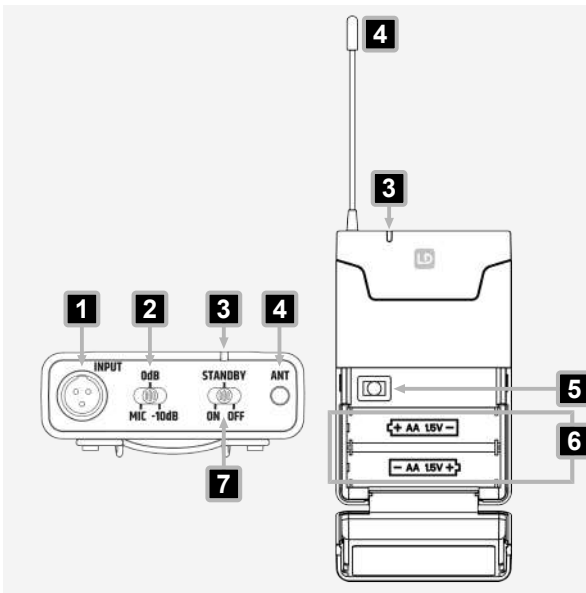

- 1 INPUT 3-pin mini-XLR jack** - Connects a headset, lavalier, instrument microphone, or guitar cable.
- 2 MIC / 0dB / -10dB slide switch** - Adjusts the input sensitivity
- 3 Status LED** - Green indicates that the charging status of the inserted batteries is sufficient. Red indicates that the battery charge is low and the batteries need to be replaced immediately
- 4 ANTENNA** - Transmits the wireless audio signal
- 5 Infrared Interface** - Synchronises the radio channels between the receiver and transmitter
- 6 Battery compartment**
- 7 ON / STANDBY / OFF slide switch** - Switches the pocket transmitter on, off, or to standby (mute)

8.7.2.2.1 MINI-XLR INPUT PIN-ASSIGNMENT OVERVIEW

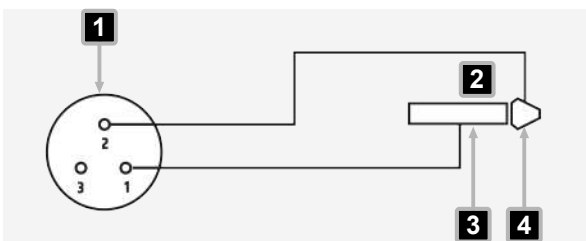

- 1 Mini-XLR**
- 2 6.3 mm jack**
- 3 Sleeve**
- 4 Tip**

8.7.2.2.2 REPLACING THE BATTERIES OF THE BODYPACK TRANSMITTER

✓ 2x batteries type AA / LR6, alkaline

- 1** Open the battery compartment.
  - a)** Press the both markings on the sides of the battery compartment.
  - b)** Fold the battery compartment cover forward.
- 2** Remove the used batteries.
- 3** Insert fresh batteries with the correct polarity, as indicated inside the battery compartment..
- 4** Press the battery compartment cover firmly until it sits flush.

⇒ A click sound confirms that the cover is securely closed.



If you won't be using the transmitter for an extended period, remove the batteries to prevent damage from potential leakage.

### 8.7.2.2.3 SYNCING A BODYPACK TRANSMITTER TO A RECEIVER

✓ You have opened the battery compartment of the bodypack transmitter to access the infrared interface.

- 1 Select a radio channel on the receiver.
- 2 Switch on the bodypack transmitter.
- 3 Press the **SYNC** button while pointing the infrared interface of the bodypack transmitter in direct visual contact with the infrared interface of the receiver.

⇒ After successful synchronisation, the red **RF** indicator LED on the receiver module lights up.

### 8.7.2.3 ADJUSTING THE INPUT SENSITIVITY OF THE BODYPACK TRANSMITTER

✓ You have switched on the receiver module of the **Anny®12**.

✓ You have a clear view of the receiver module's LED.

- 1 Select the input sensitivity level using the **MIC / 0 dB / -10 dB** slide switch.

#### EXAMPLE:

**MIC** for headset microphones

**0 dB** for guitars with passive pickups

**-10 dB** for guitars with active pickups

- 2 Test the signal from your bodypack transmitter.
  - a) Speak, sing or play.
  - b) Watch the **AF LED** on the receiver module.
- 3 Adjust or keep the input sensitivity setting according to the test result.
  - ⇒ An increase in input sensitivity is required if the **AF LED** does not light up.
  - ⇒ No adjustment is required if the **AF LED** lights up green..
  - ⇒ A decrease in input sensitivity is required if the sound is distorted or clipped.

### 8.7.2.3.1 INCREASING THE INPUT SENSITIVITY OF THE BODYPACK TRANSMITTER

✓ The **AF LED** does not light up, even though a signal is present.

- 1 Increase the input sensitivity by switching the **MIC / 0 dB / -10 dB** slide switch to the next higher setting (e.g., from -10 dB to 0 dB).
  - ⇒ The **AF LED** lights up green.
  - ⇒ The signal level is within the ideal range.

**8.7.2.3.2 DECREASING THE INPUT SENSITIVITY OF THE BODYPACK TRANSMITTER**

- ✓ The sound is distorted or clipped
- 1** Lower the input sensitivity by switching the **MIC / 0 dB / -10 dB** slide switch to the next lower setting (e.g., from 0dB to -10dB).
  - ⇒ The **AF LED** lights up green.
  - ⇒ The signal level is within the ideal range.

**8.8 OUTPUT CONNECTIONS**

**8.8.1 MIX OUT**

**8.8.1.1 LINKING DIFFERENT ANNY DEVICES VIA MIX OUTPUT**



**High sound pressure levels**

Risk of hearing damage

- a. Make sure that the main volume is turned all the way down, before you connect any input sources.



**High Sound Pressure Level**

Damage to the loudspeaker

- a. Connect line level devices, such as mixing consoles, to the line input only.

- ✓ 2 ANNY devices
  - ✓ XLR male to XLR female cable (balanced)
  - ✓ You have turned the main volume of the second device all the way down
  - ✓ You have set the second device to line-level input
- 1** Plug the XLR male connector of the cable into the combo socket (**INPUT 1** or **INPUT 2**) of the second device.
  - 2** Plug the XLR female connector of the cable into the **MIX OUTPUT** socket of the first device.

**8.9 BATTERY COMPARTMENT OVERVIEW**

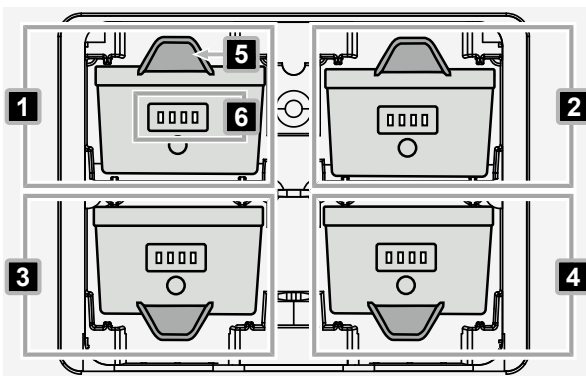

- 1** Battery slot 1
- 2** Battery slot 2
- 3** Battery slot 3
- 4** Battery slot 4
- 5** Battery retention mechanism
- 6** Charge level indicator

## 8.9.1 CHARGING DEVICE BATTERIES

✓ You have connected the **ANNY® 12** to the mains.

- 1 Flip the **POWER** switch to **ON** to operate the **ANNY® 12** and charge the internal batteries sequentially, beginning with the battery that has the lowest charge level.
- 2 Flip the **POWER** switch to **CHARGE** to charge the internal batteries simultaneously (up to four batteries at once) without operating the **ANNY® 12**.

## 8.9.2 REPLACING DEVICE BATTERIES



You can replace the batteries while the device is running. It works with anywhere from one to four batteries

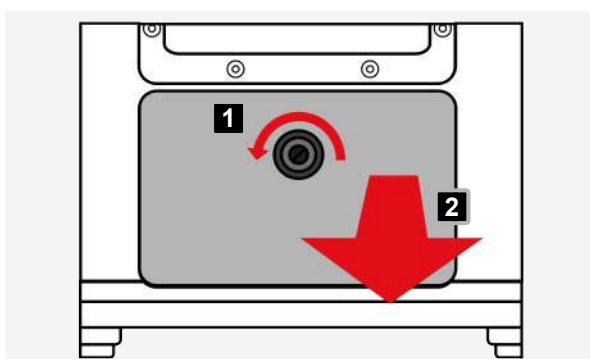

- 1 Fold the locking screw ring upwards.
- 2 Turn the locking screw ring counterclockwise to unlock the battery compartment **1**.
- 3 On the screw side, lift the battery compartment cover upwards.
- 4 Remove the battery compartment cover **2**.

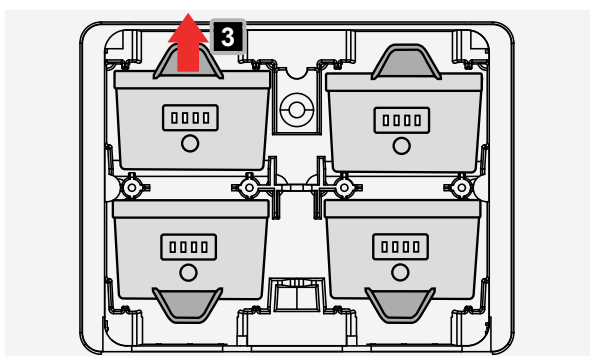

- 5 Push the retention mechanism to the outside to release the battery **3**.

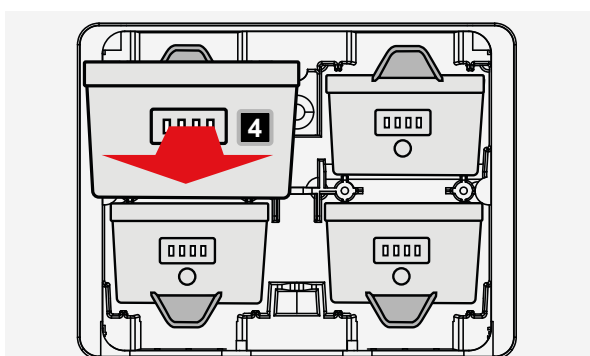

- 6 Remove the discharged battery **4**.

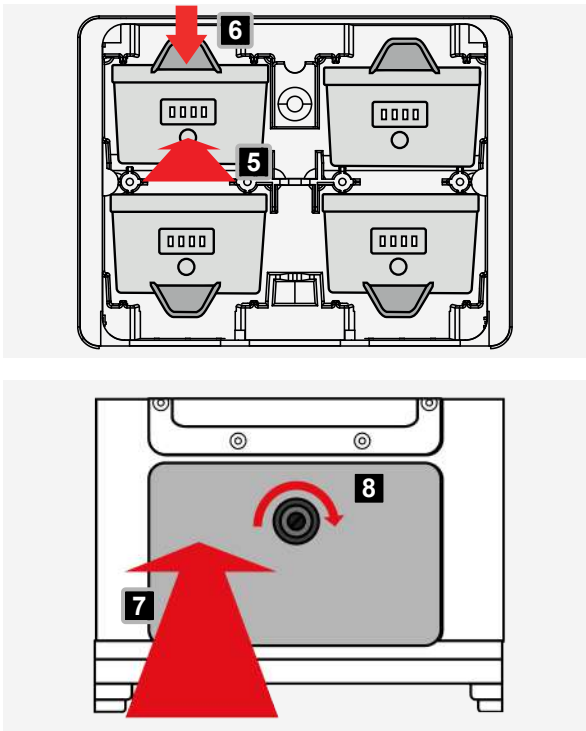

- 7 Slide the charged battery into the recess until it reaches the end stop **5** and the retention mechanism engages **6**.
- 8 Insert the battery compartment cover into the corresponding recesses.
- 9 Press the cover firmly against the battery compartment until it sits flush **7**.
- 10 Turn the locking screw clockwise to secure the cover in place **8**.

## 8.10 REPLACING THE FUSE



**The fuse holder is removed.**

Risk of electric shock due to exposed live parts

a. Do not connect the device to mains power unless the fuse holder is fully inserted.

- ✓ Fuse T3.15AL
- ✓ Flathead screwdriver
- ✓ You have powered off the device
- ✓ You have disconnected the device from the mains

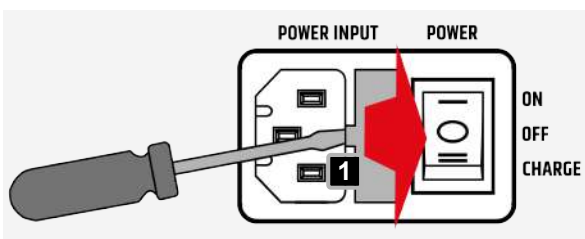

- 1 Lift the fuse compartment using a flathead screwdriver **1**.
- 2 Remove the fuse holder from the fuse holder slot.
- 3 Pullout the blown use.
- 4 Insert an intact fuse.
- 5 Slide the fuse holder back into the slot until it reaches its endstop.



## 9 MAINTENANCE

### 9.1 PRODUCT MAINTENANCE



CAUTION

#### Mains Voltage

Risk of electric shock

- a. Before you perform maintenance work on the device, disconnect the device from all poles.



NOTICE



#### Damage to the device and void of warranty

- a. Do not use cleaning agents, disinfectants, alcohol, or agents with abrasive effect for cleaning.

Carry out the maintenance measures listed below on a regular basis. The frequency of cleaning depends on the environment in which you use the product. Damp or dirty environments may cause increased soiling and wear.

#### VISUAL INSPECTION

Check the following points before operating the device.

-  **WARNING! Risk of electric shock.** Check mains power cables for damage or material fatigue.
- Check all air inlets and outlets for damage, dust, or dirt deposits.
- Check all outside screws and covers for corrosion, damage or excessive wear.
- Check all connectors and rubber sealing caps for damage, dust, or dirt deposits.
-  **WARNING! Risk of falling objects.** Check that all screws, fasteners, and rigging points are securely tightened.

#### CLEANING

- Clean the surface with a clean and damp lint-free cotton cloth. Wipe off all excess moisture.
-  **NOTICE! Do not use compressed air.** Clean any air inlets and outlets of dust and dirt deposits with a clean and damp lint-free cotton cloth.
- Clean all plug contacts from dust and dirt with a dry lint-free cotton cloth.

### 9.2 STORING THE DEVICE

Store the device only in a dry and clean environment. If you are storing the individual components of the device, use special protective covers, bags, and cases. Find such accessories for your product in the Adam Hall Shop (<https://www.adamhall.com/shop>).

### 9.3 TROUBLESHOOTING

Problem	Cause	Solution
The fuse blows once	e.g. Circuit overload	Replace the fuse
The fuse blows multiple times.	e.g. Defective components or internal short circuits	Contact the service center.
No sound from speaker, but display is on	Incorrect usage (e.g. cables, volume, signal)	Check all cables and connections, ensure volume is turned up, and verify signal on the display.
	Amplifier may be overheated	Turn the device off and wait a few minutes to allow it to cool down. Avoid direct sunlight.
	Electrical failure or damaged speaker coil	Turn off and on again. If the issue persists, <b>contact the service centre.</b>
Speaker does not turn on	No mains connection	Check if the device is properly connected to mains power.
	No charged battery installed	Make sure at least one battery is charged for battery-powered operation.
Foot pedal does not work	Incorrect wiring	Check the foot pedal wiring and ensure it is connected correctly.
Other issues	Unknown or unlisted cause	<b>Contact the service centre</b>

### 9.4 RESETTING THE DEVICE TO FACTORY SETTINGS



- 1 Push the **VOLUME rotary-push encoder (RPE)** to access the main menu.
- 2 Turn the **VOLUME RPE** until **SETTINGS** is highlighted.
- 3 Push the **VOLUME RPE** to enter the **SETTINGS** submenu.
- 4 Turn the **VOLUME RPE** until **FACTORY DEFAULT** is highlighted.
- 5 Push the **VOLUME RPE** to proceed.



- 6 Turn the **VOLUME RPE** to select **CANCEL** or **RESET**.
- 7 Push the **VOLUME RPE** to confirm the selected option.
- 8 Select **RESET** to proceed **2**.

 **CANCEL** takes you back to the main menu.

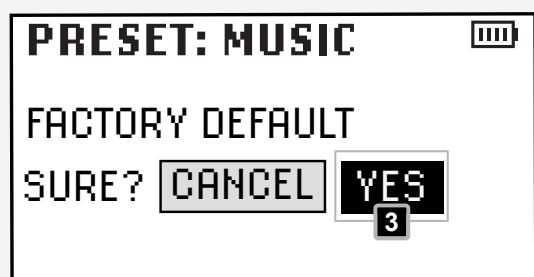

- 9 Select **YES** to reset the device to **FACTORY DEFAULT** settings **3**.
  - ⇒ The device returns to the main menu and re-sets all settings to factory defaults.

## 9.5

## REPAIR



CAUTION

**Do not repair the device.**

- a. Repairs may only be carried out by specialist personnel authorised by the manufacturer.
- b. If your device is damaged or requires service, contact the Adam Hall Customer Service.

## 10 DISPOSAL

### 10.1 PACKAGING DISPOSAL



1. You can feed the packaging into the reusable material cycle using the usual disposal methods.
2. Separate the packaging in accordance with the applicable disposal laws and recycling regulations in your country

### 10.2 DEVICE DISPOSAL



1. This device is subject to the European Directive on Waste Electrical and Electronic Equipment, as amended. WEEE Directive Waste Electrical and Electronic Equipment. Old appliances do not belong in the household waste. The old device must be disposed of via an approved disposal company or a municipal disposal facility. Observe the applicable regulations in your country.
2. Observe all disposal laws applicable in your country.
3. As a private customer, you can obtain information on environmentally friendly disposal options from the seller of the product or the appropriate regional authorities.

### 10.3 BATTERY DISPOSAL



1. Batteries must be disposed of via an approved disposal company or a municipal disposal facility. Do not dispose of batteries in the household waste.
2. Observe all disposal laws applicable in your country.
3. As a private customer, you can obtain information on environmentally friendly disposal options from the seller of the product or the appropriate regional authorities.
4. Devices with batteries that cannot be removed by the user must be taken to a collection point for electrical devices.

---

## INDEX

### C

---

Cleaning	49
Customer Service	8

### D

---

Dimensions	20
------------	----

### S

---

Scope of delivery	26
Storing	49

